

# BFCW 不銹鋼雙緩衝片撓性聯軸器 (滾珠螺桿專用)

Buffer Type Flexible Coupling  
(Application of Ball Screw)

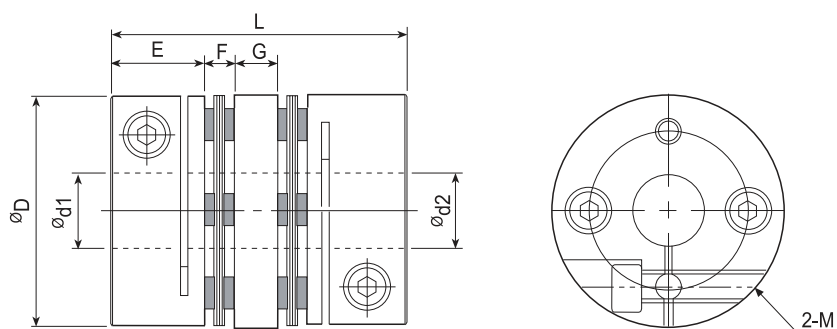

材質：鋁合金

Material: Aluminum alloy

單位(unit) : mm

型號 Model No.	$\varnothing D$	L	E	G	F	M	$\varnothing d1, \varnothing d2$ (公差: H8)	容許 偏角度 Errors of Angularity	扭矩 Rated Torque (N·m)	最高轉速 Max Rotational Frequency (rpm)	重量 Weight (g)
BFCW-19	19	27	9.4	5.8	1.2	M2.5	3 ~ 8	2°	1	10,000	18
BFCW-26	26	35	11.5	7.0	2.5	M3	5 ~ 10	2°	1.5	10,000	37
BFCW-34	34	47	14.1	10.6	3.1	M4	8 ~ 14	2°	3	10,000	77
BFCW-39	39	49	15	10.8	4.1	M4	10 ~ 16	2°	6	10,000	128
BFCW-44	44	50	15	11	4.5	M4	11 ~ 19	2°	9	10,000	162
BFCW-56	56	63	20	13	5	M5	14 ~ 24	2°	25	10,000	345
BFCW-68	68	74	24	14	6	M6	19 ~ 35	2°	55	10,000	605
BFCW-82	82	98	30	22	8	M8	24 ~ 40	2°	80	10,000	1020

訂購例：

**BFCW-44- $\varnothing 12 \times \varnothing 15$**

① ② ③ ④

- ① 型號：BFCW
- ② 外徑： $\varnothing D$
- ③ 孔徑： $\varnothing d1$
- ④ 孔徑： $\varnothing d2$

外徑 $\varnothing D34$ 以上，  
孔徑亦可加工鍵槽